

CONTO D2-Pd

Single-phase energy meter

Installation manual • Installationsanweisungen





Contents

Dangers and warnings	3
Preliminary operations	4
Presentation	4
Installation	5
Use	7
Programming	10
Communication	15
Technical characteristics	16

Inhalt

Gefahren und Warnungen	3
Vorarbeiten	4
Presentation	4
Installation	5
Verwendung	7
Programmierung	10
Kommunikation	15
Technische Daten	18

• Dangers and warnings

*This equipment must only be mounted by professionals.
The manufacturer shall not be held responsible for failure to comply with the instructions in this manual.*

Risk of electrocution, burns or explosion

- The device must only be installed and serviced by qualified personnel.
 - Prior to any work on or in the device, isolate the voltage inputs.
 - Always use an appropriate voltage detection device to confirm the absence of voltage.
 - Put all mechanisms, door and covers back in place before energising the device.
 - Always supply the device with the indicated rated voltage.
- Failure to take these precautions could cause serious injuries.*

Risk of damaging the device

Check the following:

- The voltage to the voltage-input terminals, (L - N) according to the values indicated in the "Technical characteristics" section.
- The frequency of the distribution system (50 or 60 Hz).

• Gefahren und Warnungen

*Diese Geräte dürfen nur von Fachleuten montiert werden.
Die Nichtbeachtung der vorliegenden Anweisungen entbindet den Hersteller von jeglicher Haftung.*

Stromschlag-, Verbrennungs- und Explosionsgefahr

- Die Installation und Wartung darf nur von qualifizierten Fachleuten vorgenommen werden.
 - Vor jedem Eingriff in das Gerät ist dieses spannungsfrei zu schalten.
 - Verwenden Sie immer ein geeignetes Spannungsmessgerät, um die Spannungslosigkeit zu überprüfen.
 - Alle Geräte, Anschlüsse und Abdeckungen wieder montieren, bevor Sie das Gerät unter Spannung setzen.
 - Verwenden Sie immer die angegebene Nennspannung, um das Gerät mit Strom zu versorgen.
- Die Nichtbeachtung dieser Vorsichtsmaßnahmen kann zu schweren Verletzungen führen.*

Beschädigungsgefahr des Gerätes

Bitte beachten:

- Eine Spannung an den Klemmen der Spannungseingänge (L - N) entsprechend den im Kapitel "Technische Daten" angegebenen Werten.
- Netzfrequenz 50/60 Hz

• Preliminary operations

For personnel and product safety read the contents of these operating instructions carefully before connecting. Check the following points as soon as you receive the box containing the device:

- the packing is in good condition;
- the product has not been damaged or broken during transport;
- the product reference number conforms to your order;
- the package contains both the item and the operating instructions.

• Vorarbeiten

Für die Sicherheit von Personen und Material ist es unerlässlich, den Inhalt dieser Anleitung vor der Inbetriebnahme aufmerksam zu lesen. Nach Erhalt des verpackten Gerätes, sind die folgenden Punkte zu überprüfen:

- Zustand der Verpackung;
- Überprüfung, ob Beschädigungen oder Bruch durch den Transport vorliegen;
- die Übereinstimmung zwischen Gerätecode und bestelltem Code;
- Vorhandensein des Gerätes sowie der Gebrauchsanweisung in der Verpackung.

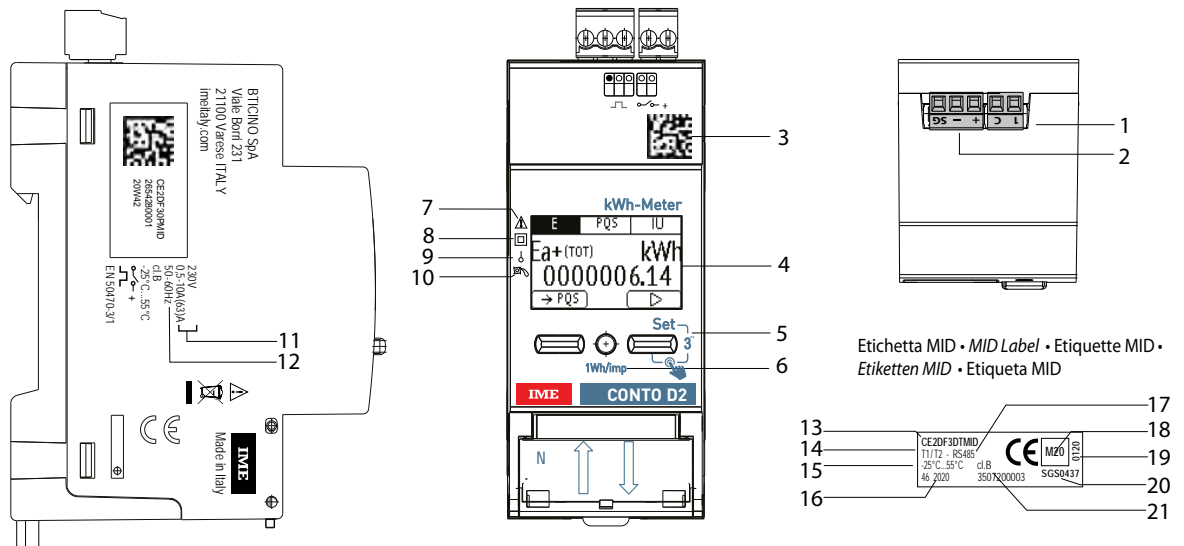

• Presentation

1. Input terminal for energy metering on double tariff
2. Pulse output connection terminal or Modbus/Mbus connection
3. Datamatrix for product traceability
4. Graphic display
5. Keypad made up of 2 double function pushbuttons (display/configuration)
6. Metrological LED
7. Consult the user manual before installation
8. Double insulation
9. Connection on single-phase line
10. Anti-rotation device (anti-decreasing)
11. Voltage/Current
12. Frequency

MID Label

13. Product code
14. Double tariff
15. Working temperature
16. Manufacturing week and year
17. Outputs
18. Year of approval
19. Certifying board
20. Certification NUMBER
21. Accuracy class

• Presentation

1. Eingangsklemme zum Zählen von Energie im Doppeltarif
2. Anschlussklemmen Impulsausgang oder Ausgang Modbus/Mbus
3. Datamatrix für die Verfolgbarkeit des Produkts
4. Graphisches Display
5. Tastatur bestehend aus 2 Tasten mit Doppelfunktion (Display/Konfiguration)
6. Metrologie LED
7. Bitte lesen Sie das Handbuch vor dem Einbau
8. Doppelisolierung
9. Einfügen in einphasige Leitung
10. Verdrehsicherung (Anti-Verringerung)
11. Spannung/Strom
12. Frequenz

Etiketten MID

13. Produktcode
14. Doppeltarif
15. Betriebstemperatur
16. Woche und Herstellungsjahr
17. Ausgänge
18. Anlegungsjahr
19. Zertifizierungsstelle
20. Zertifizierungsnummer
21. Genauigkeitsklasse

• Installation • Installation

• Recommendations

- Avoid proximity to systems which generate electromagnetic interference.

• Rezepte







- Nähe zu Generatorsystemen vermeiden elektromagnetische Störungen.

• Connection

For the maximum terminal torque see the table

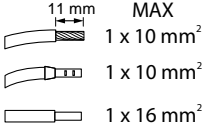
• Anschluss

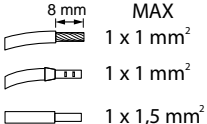
Das maximale Anzugsmoment der Klemmen finden Sie in der Tabelle

U	230V ± 15%	CAT III
I	$I_{min} = 0,25A$ $I_r = 0,5A$ $I_{ref} = 5A$ $I_{max} = 63A$	
cl.	CE2DF3DTCL1 CE2DF30PCL1	Cl. 1 Wh (EN 62053-21) Cl.2 varh (EN 62053-23)
I	$I_{min} = 0,5A$ $I_r = 1A$ $I_{ref} = 10A$ $I_{max} = 63A$ (MID)	
cl.	CE2DF30PMID CE2DF3DTMID CE2DF3MTMID	B (EN 50470-1,3)
	1 Wh/imp.	
COM	 RS485 Modbus	Mbus
	 <p>11 mm MAX 1 x 10 mm² 1 x 10 mm² 1 x 16 mm²</p>	Recommended torque 1,6 to 2Nm COMBI PZ2 
	 <p>8 mm MAX 1 x 1 mm² 1 x 1 mm² 1 x 1,5 mm²</p>	Recommended torque 0,2Nm 0,5 x 2,5mm 
	(-25°C) - (55°C)	

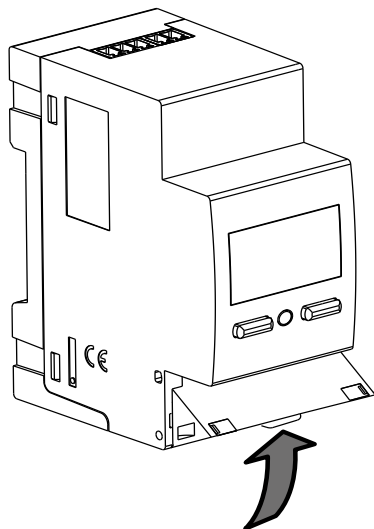

• Auxiliary supply

derived from the voltage terminals (Self-supplied)

• Hilfsversorgung

abgeleitet von den Spannungsanschlüssen (Selbstversorgung)

• Installation • Installation

• Wiring diagram • Anschlussbilder

- During wiring carefully comply with the connection diagram; a connection error may affect proper operation, or cause damage to the device.
- Beachten Sie bei der Verdrahtung unbedingt das Anschlussschema; Ungenauigkeiten in den Anschlüssen können zu Fehlbedienungen oder Schäden am Gerät führen.

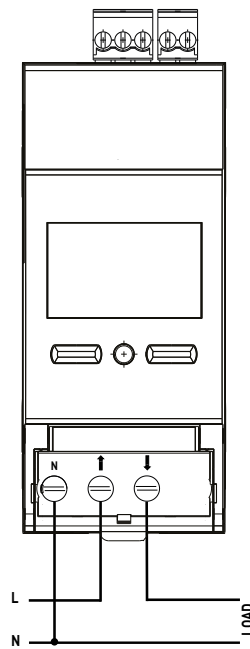

- Terminal board marking and diagram combination
- Markierung der Klemmleisten und Kombination der Anschlussbilder

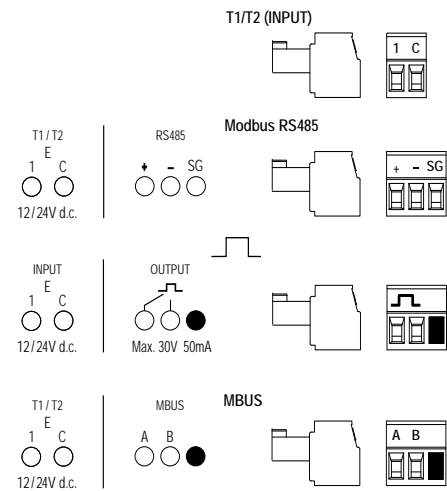

• Wiring diagram for double tariff • Schaltplan für Doppeltarif

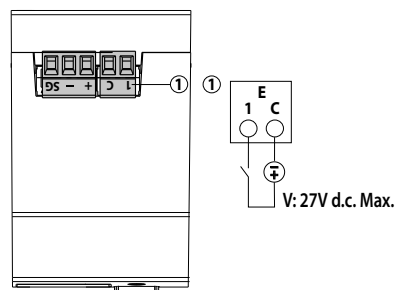

- Input connection
- Eingangsverbindung

• **Installation • Installation**

• **RS485 wiring diagram • Anschlussbilder RS485**

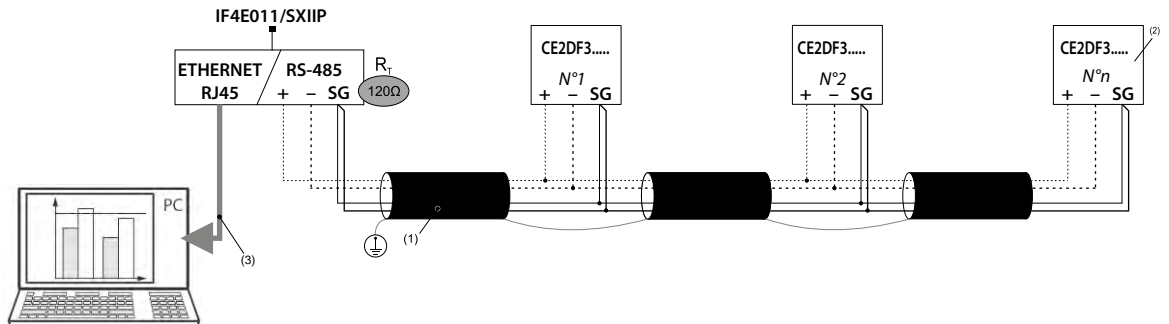

(1) max. 1000 m, Cat. 6 (FTP/UTP) max. 50 m

- (2)
- 120Ω terminating resistor inside the instrument (it can be set in the SETUP menu)
 - 120Ω Abschlusswiderstand intern im Gerät (einstellbar über das SETUP-Menü)

(3) Ethernet: Cat. 6 (FTP/UTP)

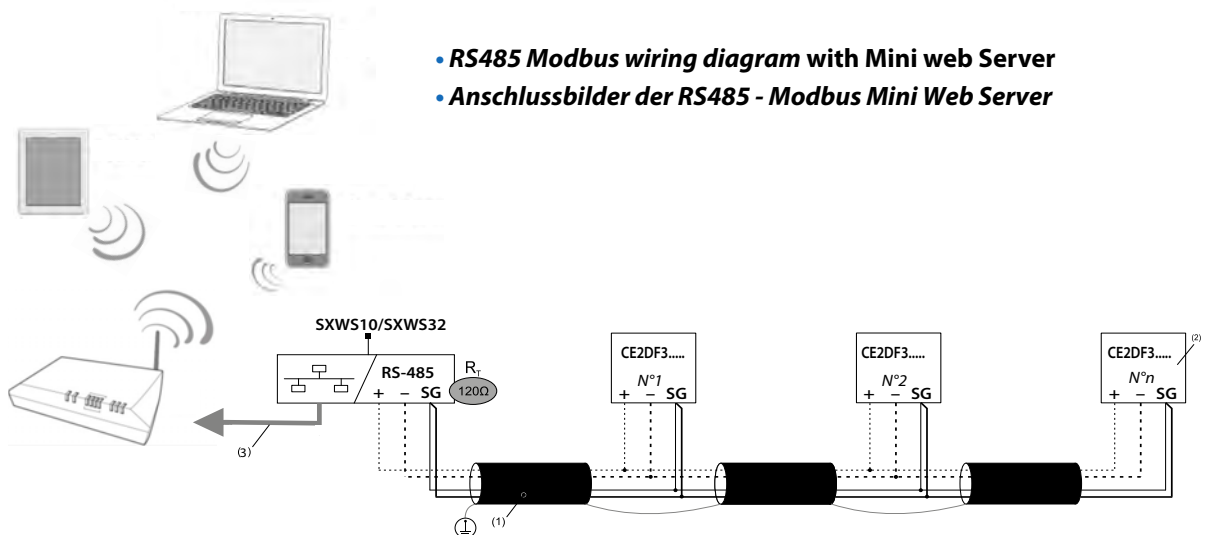

- **RS485 Modbus wiring diagram with Mini web Server**
- **Anschlussbilder der RS485 - Modbus Mini Web Server**

• **Use • Verwendung**

• **Navigation display pages**

The device is equipped with a graphic display showing the function performed by the corresponding key and is dependent on the page displayed.

• **Durchsuchen von Anzeigeseiten**

Das Gerät ist mit einem Grafikdisplay ausgestattet, das die von der entsprechenden Taste ausgeführte Funktion anzeigt und ist abhängig von der angezeigten Seite

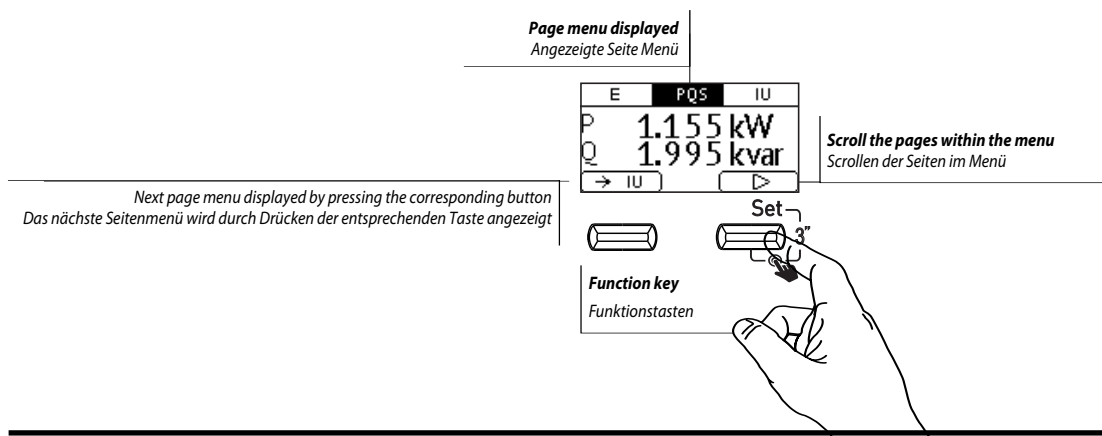

• Use • Verwendung

• Energies • Energien

On all codes
Auf allen Codes

E	PQS	IU
Ea+ (TOT)	kWh	0000003.41
→ PQS		▷
Ea- (TOT)	kWh	0000000.00
→ PQS		▷
Er+ (TOT)	kvarh	0000000.00
→ PQS		▷
Er- (TOT)	kvarh	0000000.00
→ PQS		▷

Total positive active energy
Gesamte positive Wirkenergie

Total negative active energy
Gesamte negative Wirkenergie

Total positive reactive energy
Gesamte positive Blindenergie

Total negative reactive energy
Gesamte negative Blindenergie

CE2DF3DTMID
CE2DF3MTMID
** CE2DF3DTCL1

E	PQS	IU
Ea+ (T1) ON	kWh	0000005.23
→ PQS		▷
Ea- (T1) ON	kWh	0000004.32
→ PQS		▷
Er+ (T1) ON	kvarh	0000004.31
→ PQS		▷
Er- (T1) ON	kvarh	0000001.48
→ PQS		▷
Ea+ (T2)	kWh	0000000.75
→ PQS		▷
Ea- (T2)	kWh	0000004.70
→ PQS		▷
Er+ (T2)	kvarh	0000001.28
→ PQS		▷
Er- (T2)	kvarh	0000001.26
→ PQS		▷

Total positive active energy T1/T2
Gesamte positive Wirkenergie T1/T2

Total negative active energy T1/T2
Gesamte negative Wirkenergie T1/T2

Total positive reactive energy T1/T2
Gesamte positive Blindenergie T1/T2

Total negative reactive energy T1/T2
Gesamte negative Blindenergie T1/T2

On all codes
Auf allen Codes

E	PQS	IU
Ea+ (Par)	kWh	0000003.47
→ PQS		▷ *RST
Ea- (Par)	kWh	0000000.00
→ PQS		▷ *RST
Er+ (Par)	kvarh	0000000.00
→ PQS		▷ *RST
Er- (Par)	kvarh	0000000.00
→ PQS		▷ *RST

Partial positive active energy
Positive Teilwirkenergie

Negative partial active energy
PNegative Teilwirkenergie

Positive partial reactive energy
Positive Teilblindenergie

Partial negative reactive energy
Negative Teilblindenergie

CE2DF30PMID
CE2DF30PCL1
* CE2DF3DTCL1

E	PQS	IU
Pulse Input	Wh	0000000.00
→ PQS		▷ *RST

Pulse counter
Impulszähler

• Use • Verwendung

• Powers • Leistungen

On all codes
Auf allen Codes

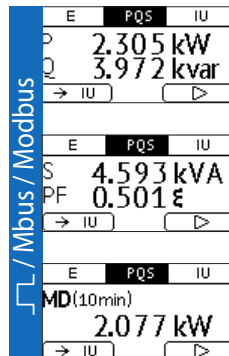

Phase active and reactive powers
Wirk- und Blindleistung

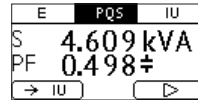

Apparent power and power factor (Ind./Cap.)
Scheinleistung und Leistungsfaktor (Ind./Kap.)

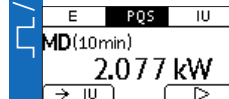

Power demand / tempo integrazione
Mittlere Leistung / Integrationszeit

CE2DF3DTMID
CE2DF3MTMID
** CE2DF3DTCL1

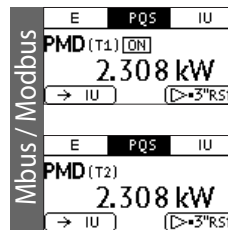

Power Max. demand T1
Mittlere Leistungsspitze T1

CE2DF30PMID
CE2DF30PCL1
* CE2DF3DTCL1

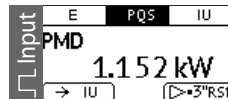

Power Max. demand
Mittlere Leistungsspitze

Nota * Page viewable only if the input configuration has been programmed as "Input mode Pulse"
** Page viewable only if the input configuration has been programmed as "Input mode Tariff"

Nota * Seite nur sichtbar, wenn die Eingangskonfiguration als "Input mode Pulse"
** Seite nur sichtbar, wenn die Eingangskonfiguration als "Input mode Tariff"

• Voltages and currents • Spannungen und Ströme

On all codes
Auf allen Codes

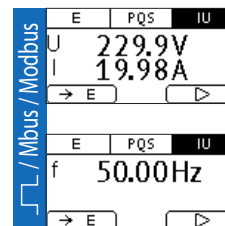

Phase voltages and current
Phasenspannungen und -ströme

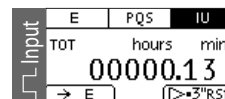

Network frequency
Netzfrequenz

CE2DF30PMID
CE2DF30PCL1
* CE2DF3DTCL1

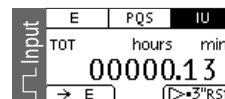

Hour counter
Zeitähler

CE2DF3DTMID
CE2DF3MTMID
** CE2DF3DTCL1

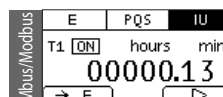

Hour counter T1/T2
Zeitähler T1/ T2

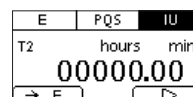

- Reset
- Rücksetzen

Nota: Reset is possible only in the pages where 3 "Rst" appears
Nota: Ein Zurücksetzen ist nur auf den Seiten möglich, auf denen 3 "Rst" zuerst angezeigt wird

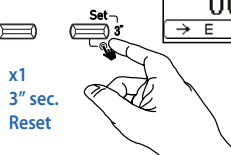
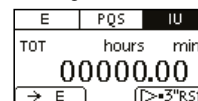

• Programming • Programmierung

- Keeping the key **Set** pressed for 3 " accesses the setup parameters display.
- Durch Drücken der Taste **Set** für 3 " wird die Anzeige der Setup-Parameter aufgerufen.

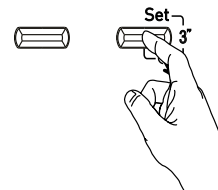

Modbus CE2DF3DTCL1 CE2DF3DTMID

MID / no MID	SETUP Address 001 SET >	RS485 address Adresse RS485
	SETUP Baudrate 38.4 kbit/s SET >	Communication speed Kommunikationsgeschwindigkeit
	SETUP Parity Even SET >	Parity bit Paritätsbit
	SETUP RX time 15 ms SET >	Required response time to request Antwortzeit auf Abfrage
	SETUP Termination None SET >	Termination resistance Abschlusswiderstand
	SETUP Protocol Standard SET >	Protocol type Protokolltyp
	SETUP Int. time (MD) 10 Minutes SET >	Average Power integration time Durchschnittliche Leistungs-Integrationszeit
no MID	SETUP Run hours thr 10.00 % SET >	Start counting Zählerstart
	SETUP Input mode Pulse SET >	Input configuration Eingangskonfiguration
	SETUP In.pulse unit Wh SET >	Input pulse measurement unit Messeingangsimpuls Einheit
MID / no MID	SETUP In.pulse weight 000.01 Wh SET >	Input pulse weight Eingangsimpulswertigkeit
	SETUP Change psw 0000 SET >	Change Password Passwort ändern
	SETUP IM-CE2DF3 Version: 0.000 Crc: 00000 >EXIT	CRC Software CRC Software

• Programming • Programmierung

- Keeping the key **Set** pressed for **3 "** accesses the setup parameters display.
- Durch Drücken der Taste **Set** für **3 "** wird die Anzeige der Setup-Parameter aufgerufen.

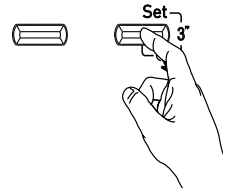

Mbus CE2DF3MTMID

MID / no MID	SETUP Primary Address 001 SET ▶	Primary address Primäradresse
	SETUP Second. Address 00000000 SET ▶	Secondary address Sekundäre Adresse
	SETUP Baudrate 2400 bit/s SET ▶	Communication speed Kommunikationsgeschwindigkeit
	SETUP Int. time (MD) 10 Minutes SET ▶	Average Power integration time Durchschnittliche Leistungs-Integrationszeit
	SETUP Run hours thr 10.00 % SET ▶	Start counting Zählbeginn
no MID	SETUP Input mode Pulse SET ▶	Input Eingangskonfiguration
	SETUP In.pulse unit Wh SET ▶	Input pulse measurement unit Messeingangsimpuls Einheit
	SETUP In.pulse weight 000.01 Wh SET ▶	Input pulse weight Eingangsimpulswertigkeit
MID / no MID	SETUP Change psw 0000 SET ▶	Change Password Passwort ändern
	SETUP IM-CE2DF3 Version: 0.000 Crc: 00000 ▶*EXIT	CRC Software CRC Software

• Programming • Programmierung

- Keeping the key **Set** pressed for **3 "** accesses the setup parameters display.
- Durch Drücken der Taste **Set** für **3 "** wird die Anzeige der Setup-Parameter aufgerufen.

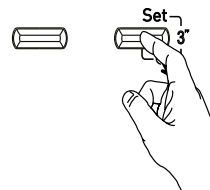

CE2DF30PCL1
CE2DF30PMID

MID / no MID	SETUP Out pulse type Ea+ (TOT) SET ▶	Type of energy to be translated on the pulse output <i>Energieart, die dem Impulsausgang zugeordnet ist</i>
	SETUP Out pulse weight 10 Wh SET ▶	Pulse Weight (kWh) <i>Impulswertigkeit (kWh)</i>
	SETUP Out pulse length 100mS SET ▶	Width of the pulse (msec) <i>Impulsdauer (msec)</i>
	SETUP Int. time (MD) 10 Minutes SET ▶	Average Power integration time <i>Durchschnittliche Leistungs-Integrationszeit</i>
	SETUP Run hours thr 10.00 % SET ▶	Start counting <i>Zählbeginn</i>
	SETUP In.pulse unit Wh SET ▶	Input pulse measurement unit <i>Messeingangsimpuls Einheit</i>
	SETUP In.pulse weight 000.01 Wh SET ▶	Input pulse weight <i>Eingangsimpulswertigkeit</i>
	SETUP Change psw 0000 SET ▶	Change Password <i>Passwort ändern</i>
IM-CE2DF3 Version: 0.000 Crc: 00000 ▶EXIT	CRC Software CRC Software	

• Programming • Programmierung

• Changing SETUP data • Ändern der Setup-Daten

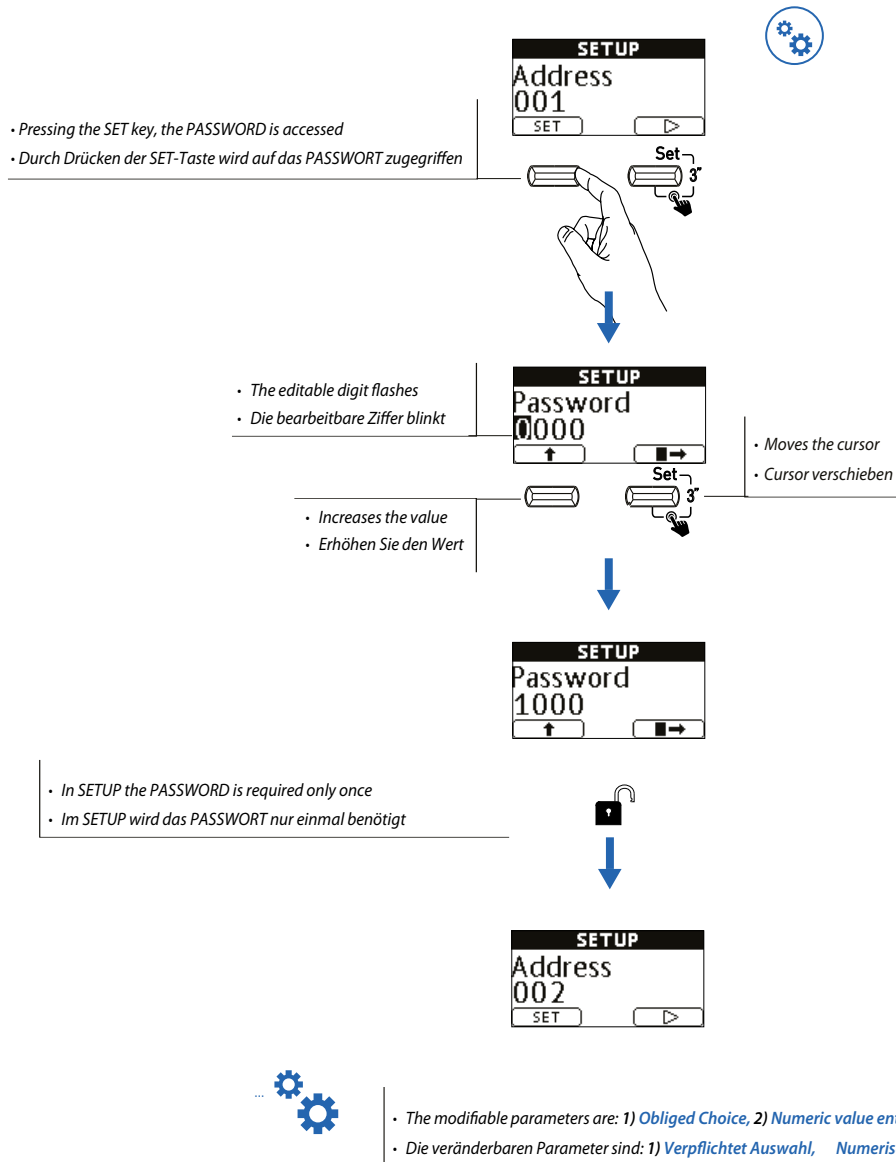

• Programmation • Programmierung

- **The modifiable parameters are:** • **Die einstellbaren Parameter sind:**

1

- Obligated Choice
- Verpflichtet Auswahl



- The editable digit flashes
- Die bearbeitbare Ziffer blinkt



- Change the choice
- Ändern Sie die Auswahl



- Save the change and move to the next setup
- Speichern Sie die Änderung und fahren Sie mit dem nächsten Setup fort

2

- Numeric value entry
- Numerische Werteingabe

- The editable digit flashes
- Die bearbeitbare Ziffer blinkt

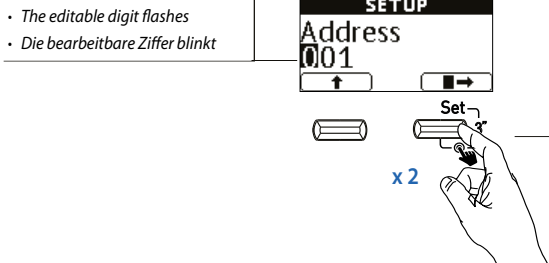
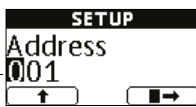

- Move to the next digit modified
- Bewegen Sie zur nächsten Stelle geändert

- Increases the value
- Erhöhen Sie den Wert

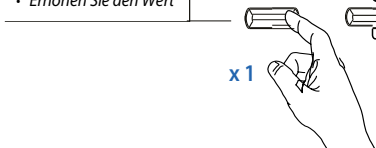

- Save
- Speichern

• Communication

The "**CE2DF3DTCL1 - CE2DF3DTMID**" energy counters communicate using the MODBUS® protocol which implies a dialogue using a master-slave logic structure.

Addressing type:

- point-point (the master communicates one slave at once).

The communication takes place with RTU (Remote Terminal Unit) mode.

Communication syntax

For the standard communication syntax, refer to the Modbus communication table

According to the MODBUS® protocol, for the "**CE2DF3DTCL1 - CE2DF3DTMID**" to consider the message to be valid, the maximum waiting time between two parts of the message itself must be less than 3.5 times the "intercharacter time" (character = 8bit data).

Communication table

> The MODBUS communication tables are available on the <http://www.imeitaly.com/> site entering the "**CE2DF3DTCL1 - CE2DF3DTMID**" codes in the search field

• Kommunikation

Die Energiezähler "**CE2DF3DTCL1 - CE2DF3DTMID**" kommunizieren über das MODBUS®-Protokoll, welches einen Dialog nach einer Master/Slave-Logik entspricht.

Adressierungsart:

- Punkt-zu-Punkt (der Master kommuniziert mit jeweils nur einem Slave-Gerät).

Die Kommunikation erfolgt im RTU-Modus (Remote Terminal Unit).

Kommunikationssyntax





































Die Standard-Kommunikationssyntax entnehmen Sie bitte der Modbus-Kommunikationstabelle.

Nach dem MODBUS®-Protokoll muss die maximale Wartezeit zwischen zwei Datenpakete der Nachricht, selbst weniger als das 3,5-fache der sogenannten "Zwischenzeit" (Zeichen = 8 Bit Daten) betragen, damit eine Nachricht von "**CE2DF3DTCL1 - CE2DF3DTMID**" als gültig betrachtet werden kann.

Kommunikationstabelle

> Die MODBUS-Kommunikationstabellen stehen unter <http://www.imeitaly.com/> zur Verfügung, indem Sie im Suchfeld die Codes "**CE2DF3DTCL1 - CE2DF3DTMID**" eingeben.

• Technical characteristics











































Case																		
Dimension (w x h x d)	35,8 x 92,4 x 66mm																	
Connections	<table border="1" style="width: 100%; border-collapse: collapse;"> <tr> <td style="text-align: center;">  L-N </td> <td style="text-align: center;">  11 mm MAX 1 x 10 mm² </td> <td rowspan="3" style="text-align: center; vertical-align: middle;"> Recommended torque 1,6 to 2Nm COMBI PZ2  </td> </tr> <tr> <td></td> <td style="text-align: center;">  1 x 10 mm² </td> </tr> <tr> <td></td> <td style="text-align: center;">  1 x 16 mm² </td> </tr> <tr> <td></td> <td style="text-align: center;">  1 C </td> <td style="text-align: center;">  8 mm MAX 1 x 1 mm² </td> <td rowspan="3" style="text-align: center; vertical-align: middle;"> Recommended torque 0,2Nm 0,5 x 2,5mm  </td> </tr> <tr> <td></td> <td style="text-align: center;">  RS485 </td> <td style="text-align: center;">  1 x 1 mm² </td> </tr> <tr> <td></td> <td style="text-align: center;">  MBUS </td> <td style="text-align: center;">  1 x 1,5 mm² </td> </tr> </table>	 L-N	 11 mm MAX 1 x 10 mm ²	Recommended torque 1,6 to 2Nm COMBI PZ2 		 1 x 10 mm ²		 1 x 16 mm ²		 1 C	 8 mm MAX 1 x 1 mm ²	Recommended torque 0,2Nm 0,5 x 2,5mm 		 RS485	 1 x 1 mm ²		 MBUS	 1 x 1,5 mm ²
 L-N	 11 mm MAX 1 x 10 mm ²	Recommended torque 1,6 to 2Nm COMBI PZ2 																
	 1 x 10 mm ²																	
	 1 x 16 mm ²																	
	 1 C	 8 mm MAX 1 x 1 mm ²	Recommended torque 0,2Nm 0,5 x 2,5mm 															
	 RS485	 1 x 1 mm ²																
	 MBUS	 1 x 1,5 mm ²																
Degree of protection	Front face IP54, Terminals IP20																	
Weight:	130g																	
Display																		
Type:	Graphic, backlit 1.2 inches (128x64)																	
Auxiliary supply																		
Derived from the voltage terminals (Self-supplied)																		
Measurement																		
Single-phase network																		
Voltage (TRMS) Direct measurement																		
Single-phase rated voltage Un:	230V ~ ± 15%																	
Power consumption voltage circuit:	Max. 1,5VA																	
Current (TRMS) Direct measurement																		
	$I_{min}: 0,25A - I_{tr}: 0,5A - I_b: 5A - I_{max}: 63A$																	
	$I_{min}: 0,5A - I_{tr}: 1A - I_b: 10A - I_{max}: 63A (MID)$																	
Current circuit power consumption	Max. 1,8W																	
Short-time overcurrent (IEC/EN 62053-21, IEC/EN 62053-23):	30 I _{max} / 10ms																	
Frequency																		
Rated frequency	F _n 50Hz; 60Hz																	
Permitted variation	49...51 Hz, 59...61Hz																	
Energies																		
Cod. CE2DF30PCL1 - CE2DF3DTCL1	Active energy accuracy class: 1 (IEC/EN 62053-21) Reactive energy accuracy class: 2 (IEC/EN 62053-23)																	
Cod. CE2DF30PMID - CE2DF3DTMID - CE2DF3MTMID	Accuracy class: B (EN 50470-1, -3)																	

• Technical characteristics

Digital inputs	
Voltage:	12-24V DC
Current:	Max. 10 mA
Pulse output	
Type:	Optorelays with potential-free SPST-NO contact
Voltage:	Max. 27 V AC/DC
Current:	Max. 50 mA
Operating conditions	
Operating temperature:	(-25°C) ÷ (55°C) [-13°F ÷ 131°F]
Storage temperature:	(-25°C) ÷ (70°C) [-13°F ÷ 158°F]
Humidity:	Suitable for tropical climates
Max. dissipated power:	≤ 10 W
Mechanical environment:	M1
Electromagnetic environment:	E2
Relative humidity:	95% not condensing (EN50472-1)
Installation:	Mounting the KWH-meter in a IP51 switchboard
Use:	Indoor

CE Marking	
<p>The CE2DF30PCL1 - CE2DF3DTCL1 - CE2DF30PMID - CE2DF3DTMID - CE2DF3MTMID devices comply with:</p> <ul style="list-style-type: none"> • The requirements of the European directive on electromagnetic compatibility (EMC) n° 2014/30/EU • The low voltage directive n° 2014/35/UE. • Directive 2011/65/EU modified by directive 2015/863 (RoHS 2). 	
Electromagnetic compatibility	
According to IEC/EN 62052-11 - EN 50470-1	
Insulation (IEC/EN 62052-11, IEC/EN 62053-21)	
Measurement category:	III
Degree of pollution:	2
Insulation voltage, U _i :	300V Phase-Earth
Impulse withstand voltage	<ul style="list-style-type: none"> - Measuring inputs / Digital I/O inputs wave 1,2 / 50µs 0,5 J: 6,3kV alternate voltage 50Hz / 1 min.: 4kV - All circuits / earth alternate voltage 50Hz / 1 min.: 4kV
Front surface:	Class II

• Technische Daten

Gehäuse							
Abmessung (L x H x T)	35,8x 92,4 x 66mm						
Anschlüsse	<table border="1" style="width: 100%; border-collapse: collapse;"> <tr> <td style="text-align: center;">  L-N </td> <td style="text-align: center;">  11 mm MAX  1 x 10 mm²  1 x 10 mm²  1 x 16 mm² </td> <td style="text-align: center;"> Recommended torque 1,6 to 2Nm COMBI PZ2  </td> </tr> <tr> <td style="text-align: center;">  1 C  RS485  MBUS </td> <td style="text-align: center;">  8 mm MAX  1 x 1 mm²  1 x 1 mm²  1 x 1,5 mm² </td> <td style="text-align: center;"> Recommended torque 0,2Nm 0,5 x 2,5mm  </td> </tr> </table>	 L-N	 11 mm MAX  1 x 10 mm ²  1 x 10 mm ²  1 x 16 mm ²	Recommended torque 1,6 to 2Nm COMBI PZ2 	 1 C  RS485  MBUS	 8 mm MAX  1 x 1 mm ²  1 x 1 mm ²  1 x 1,5 mm ²	Recommended torque 0,2Nm 0,5 x 2,5mm 
 L-N	 11 mm MAX  1 x 10 mm ²  1 x 10 mm ²  1 x 16 mm ²	Recommended torque 1,6 to 2Nm COMBI PZ2 					
 1 C  RS485  MBUS	 8 mm MAX  1 x 1 mm ²  1 x 1 mm ²  1 x 1,5 mm ²	Recommended torque 0,2Nm 0,5 x 2,5mm 					
Schutzklasse:	Frontal IP54, Klemmen IP20						
Gewicht:	130 g						
Display							
Typ:	Hintergrundbeleuchtete LCD-Anzeige, 1,2 Zoll (128x64)						
Hilfsspannung							
Abgenommen von den Messspannungsanschlüssen (Selbstversorgung)							
Messung							
Einphasennetz							
Spannung (TRMS) Direkte Messung							
Einphasen Nennspannung Un:	230V ~ ± 15%						
Eigenverbrauch des Spannungskreis	Max. 1,5VA						
Strom (TRMS) Direkte Messung	$I_{min}: 0,25A - I_{tr}: 0,5A - I_b: 5A - I_{max}: 63A$						
	$I_{min}: 0,5A - I_{tr}: 1A - I_b: 10A - I_{max}: 63A (MID)$						
Eigenverbrauch des Stromkreis	Max. 1,8W						
Kurzzeitige Überlastung (IEC/EN 62053-21, IEC/EN 62053-23):	30 I _{max} / 10ms						
Frequenz							
Nennfrequenz	F _n 50Hz; 60Hz						
Spannungsanschlussklemmen	49...51 Hz, 59...61Hz						
Energie							
Cod. CE2DF30PCL1 - CE2DF3DTCL1	Genauigkeitsklasse Wirkenergie: 1 (IEC/EN 62053-21) Genauigkeitsklasse Blindenergie: 2 (IEC/EN 62053-23)						
Cod. CE2DF30PMID - CE2DF3DTMID - CE2DF3MTMID	Genauigkeitsklasse: B (EN 50470-1, -3)						

• Technische Daten

Digitaleingänge	
Spannung:	12-24V DC
Strom:	Max. 10 mA
Impulsausgang	
Typ:	Optorelais mit SPST-NO Kontakt potentialfrei
Spannung:	Max. 27 V AC/DC
Strom:	Max. 50 mA
Gebrauchsbedingungen	
Arbeitstemperatur:	(-25°C) ÷ (55°C) [-13°F ÷ 131°F]
Lagertemperatur:	(-25°C) ÷ (70°C) [-13°F ÷ 158°F]
Feuchtigkeit:	Geeignet für den Einsatz in tropischem Klima
Maximale Verlustleistung:	≤ 10 W
Mechanische Umgebung:	M1
Elektromagnetische Umgebung:	E2
Relative Feuchte:	95% ohne Kondensation (EN50472-1)
Installieren:	Montage des Zählers innerhalb eines IP51-Panels
Anwendung:	Interne Verwendung

CE-Kennzeichnung	
Die Geräte CE2DF30PCL1 - CE2DF3DTCL1 - CE2DF30PMID - CE2DF3DTMID - CE2DF3MTMID entsprechen <ul style="list-style-type: none"> • Den Bestimmungen der Europäischen Richtlinie über die elektromagnetische Verträglichkeit (EMV) Nr. 2014/30/EU • Der Niederspannungsrichtlinie 2014/35/EU • Der Richtlinie 2011/65/EG geändert durch Richtlinie 2015/863 (RoHS 2) 	
Elektromagnetische Verträglichkeit	
Prüfungen gemäß IEC/EN 62052-11 - EN 50470-1	
Isolation (IEC/EN 62052-11, IEC/EN 62053-21)	
Messkategorie:	III
Verschmutzungsgrad:	2
Isolationsspannung, U _i :	300V Phase-Erde
Impulstestspannung:	-Messeingänge / Digitale I / O-Eingänge: Welle 1,2 / 50µs 0,5 J: 6,3kV Wechselspannung 50Hz / 1 min.: 4kV -Alle Stromkreise / Masse Wechselspannung 50Hz / 1 min.: 4kV
Frontfläche:	Klasse II